

# AIR BALANCER RAIL SYSTEM

# ENDO



## ENDO ENDO KOGYO CO., LTD.

3-14-7, Akibacho, Tsubame, Niigata, Japan  
TEL : +81-256-62-5131 FAX. +81-256-62-5772

<http://www.endo-kogyo.co.jp>



ISO9001 JP97/010458  
SCOPE : Head office, Plant



ISO14001 JP10/070952  
SCOPE : Head office, Plant

## ENDO ENDO KOGYO INDIA PVT. LTD.

101, First Floor, Aditya Towers  
LullaNagar, Off Kondhwa Road, Pune - 411 040  
TEL : +91-86-00042752 Mail. [info@endo-india.co.in](mailto:info@endo-india.co.in)  
<http://www.endo-india.co.in>



### Type- **MS-A** Hoisting "WITH" DOWN STOP

**AIR BALANCER is handling equipment powered by compressed air.**

- **Adjustment of lifting and lowering speed**

Both speeds are adjustable by turning the knob on control module.

- **Floating capability**

By adding or reducing force directly onto the hung load, the load will move down or up respectively. The range of floating is about 35cm up and down from stable position.



Grip for operation

Pendant for operation

Grip for operation



EHB-85+MS-AG



Control module MS-A

Pendant for operation

EHB-85+MS-A

Control module	Model	Hose	Operation	Weight	Body
Hoisting	MS-A	Straight hose×3	Pendant	3.5kg	All model
Hoisting	MS-AG	Coil hose×3	Grip	5kg	EHB-50S(C),50(C),85(C),130(C),270(C)

### Specification

( ) Show performances of the chain type

Model	Air pressure (MPa)	Max lifting capacity (kg)	Stroke (m)	Weight (kg) (*)	Cable dia (Wire rope type)	Chain size×Fall (Chain type)	Air inlet
EHB-50S EHB-50SC	0.7	55	0.7 (0.65)	21 (20)	φ4.76	4.0×1	Rc 3/8
	0.6	48					
	0.5	40					
EHB-50 EHB-50C	0.7	55	1.9 (1.8)	28 (29)			
	0.6	48					
	0.5	40					
EHB-85 EHB-85C	0.7	90	1.9 (1.8)	29 (30)			
	0.6	75					
	0.5	62					
EHB-130 EHB-130C	0.7	140	1.9 (1.8)	36 (37)			
	0.6	120					
	0.5	100					
EHB-270 EHB-270C	0.7	270	1.9 (1.7)	43 (44)	φ6		
	0.6	230					
	0.5	190					
EHB-270CR	0.7	270	0.9	43	—	4.0×2	
	0.6	230					
	0.5	190					
EHB-450CR	0.6	450	0.85	50			
	0.5	370					
	0.4	290					

(\*) Weight: Without module

**POINT**

- **Grip type controller**

Grip type controller allows a more sensitive control of height of lift.

- **DOWN STOP**

Added safety measure. Hung load will not fall even if the air supply is cut off or when hoses are broken.

- **Energy-saving design**

Air consumption of AIR BALANCER is only 1/7 of that of AIR HOIST. (comparing our existing model)

- **Clean design**

No lubrication is needed and produces no oil mist.

- **Quiet design**

With no air motor, AIR BALANCER produces very little noise in operation.

## Type-MS/MSS Hoisting "WITHOUT" DOWN STOP

### ● Adjustment of lifting and lowering speed

Both speeds are adjustable by turning the knob on control module

### ● Floating capability

By adding or reducing force directly onto the hung load, the load will move down or up respectively. The range of floating is about 35cm up and down from stable position.



Control module	Model	Hose	Operation	Weight	Body
Hoisting	MS	Straight hose×2	Pendant	2kg	EHB-50S(C),50(C),85(C),130(C),270CR
Hoisting	MSS	Straight hose×2	Pendant	2.2kg	EHB-270(C),450CR

### Specification

( ) Show performances of the chain type

Model	Air pressure (MPa)	Max lifting capacity (kg)	Stroke (m)	Weight (kg) (*)	Cable dia (Wire rope type)	Chain size×Fall (Chain type)	Air inlet			
EHB-50S EHB-50SC	0.7	55	0.7 (0.65)	21 (20)	φ4.76	4.0×1	Rc 3/8			
	0.6	48								
	0.5	40								
EHB-50 EHB-50C	0.4	32	1.9 (1.8)	28 (29)						
	0.7	55								
	0.6	48								
EHB-85 EHB-85C	0.5	40	1.9 (1.8)	29 (30)						
	0.4	32								
	0.7	90								
EHB-130 EHB-130C	0.6	75	1.9 (1.7)	36 (37)				φ6	4.0×2	
	0.5	40								
	0.4	80								
EHB-270 EHB-270C	0.7	270	0.9	43 (44)						
	0.6	230								
	0.5	190								
EHB-270CR	0.4	150	—	43						
	0.6	230								
	0.5	190								
EHB-450CR	0.4	150	0.85	50						
	0.6	450								
	0.5	370								
	0.4	290								

(\*) Weight: Without module

**POINT**

### ● Economical model

### ● energy-saving design

Air consumption of AIR BALANCER is only 1/7 of that of AIR HOIST. (comparing our existing model)

### ● Clean design

No lubrication is needed and produces no oil mist.

### ● Quiet design

With no air motor, AIR BALANCER produces very little noise in operation.

### NOTICE

DOWN STOP is available when the air supply is stopped but it is "NOT" available when hose for lowering control is cut.

### Type-ABC Full auto module

#### ● Auto Balance

With Full auto module, the AIR BALANCER can automatically adjust itself to the weight of the hung load. The load can then be lifted and lowered by hand without using the controller.

#### ● Adjustment of lifting and lowering speed

Both speeds are adjustable by turning the knob on control module.

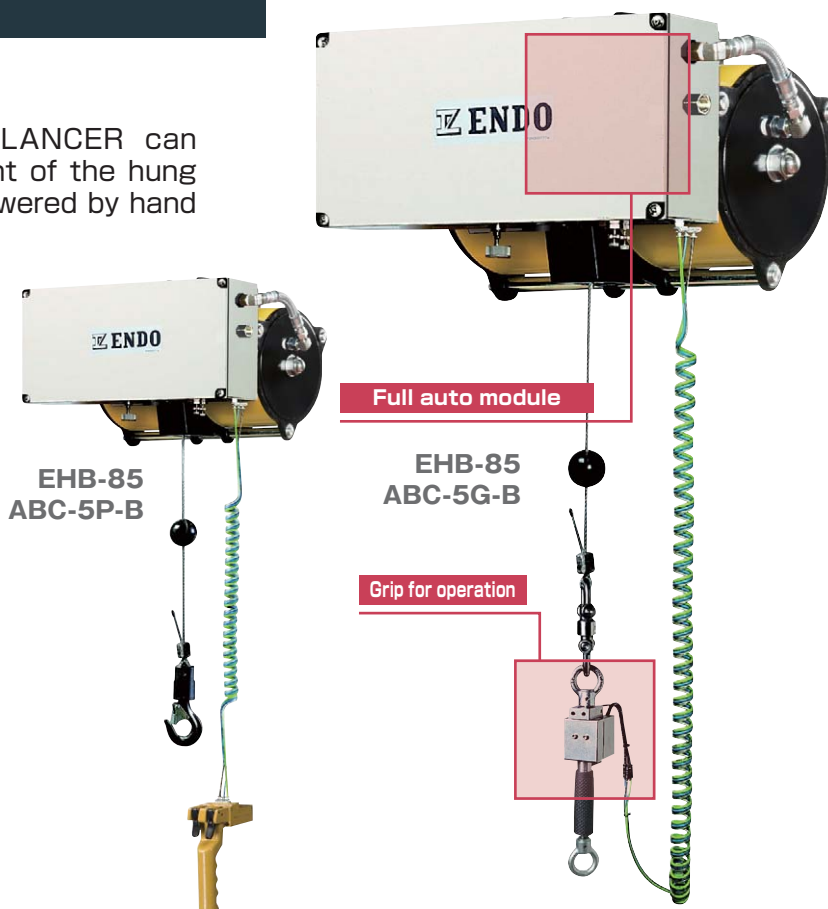

Control module	Model	Hose	Operation	Weight	Body
Full auto module	ABC-5P-B	Coil hose×3	Pendant	11kg	EHB-50S(C),50(C),85(C),130(C),270CR
Full auto module	ABC-5G-B	Coil hose×3	Grip	11kg	EHB-50S(C),50(C),85(C),130(C)

### Specification

( ) Show performances of the chain type

Model	Air pressure (MPa)	Max lifting capacity (kg)	Stroke (m)	Weight (kg) (*)	Cable dia (Wire rope type)	Chain size×Fall (Chain type)	Air inlet
EHB-50 EHB-50C	0.5	40	1.9 (1.8)	28 (29)	φ4.76	4.0×1	Rc 3/8
	0.4	30					
	0.3	20					
EHB-85 EHB-85C	0.5	60	1.9 (1.8)	29 (30)			
	0.4	45					
	0.3	30					
EHB-130 EHB-130C	0.5	85	1.9 (1.8)	36 (37)			
	0.4	62.5					
	0.3	40					
EHB-270CR	0.5	160	0.9	43	—	4.0×2	
	0.4	115					
	0.3	70					

(\*) Weight: Without module

**POINT**

#### ● Auto Balance

Full auto module can recognize the weight of hung device from 0kg to Max lifting capacity so that the balancing can be controlled.

#### ● DOWN STOP

Added safety measure. Hung load will not fall even if the air supply is cut off or when hoses are broken.

#### ● Energy-saving design

Air consumption of AIR BALANCER is only 1/7 of that of AIR HOIST. (comparing our existing model)

#### ● Clean design

No lubrication is needed and produces no oil mist.

#### ● Quiet design

With no air motor, AIR BALANCER produces very little noise in operation.

## Type-MSD Hoisting with inertia prevention unit

### ● Adjustment of lifting and lowering speed

Both speeds are adjustable by turning the knob on control module.



EHB-85D MSD

Control module MSD

Pendant for operation

### Inertia prevention unit

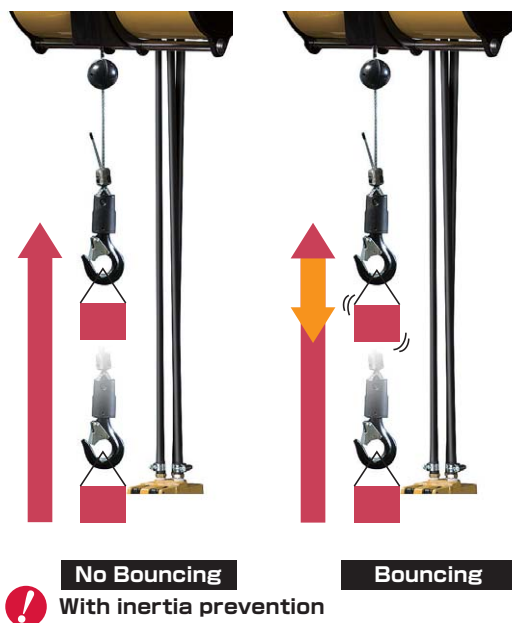

No Bouncing With inertia prevention

Bouncing

Control module	Model	Hose	Operation	Weight	Body
Hoisting	MSD	Straight hose×3	Pendant	6kg	EHB-85D

### Specification

Model	Air pressure (MPa)	Max lifting capacity (kg)	Stroke (m)	Weight (kg) (*)	Cable dia (mm)	Air inlet
EHB-85D	0.7	90	1.9	34	φ4.76	Rc 3/8
	0.6	75				
	0.5	62				
	0.4	50				

(\*)Weight: Without module

**POINT**

#### ● Inertia prevention unit

Accurate positioning by pendant control is made possible. (Brake eliminates the bouncing effect)

#### ● DOWN STOP

Added safety measure. Hung load will not fall even if the air supply is cut off or when hoses are broken.

#### ● Energy-saving design

Air consumption of AIR BALANCER is only 1/7 of that of AIR HOIST. (comparing our existing model)

#### ● Clean design

No lubrication is needed and produces no oil mist.

#### ● Quiet design

With no air motor, AIR BALANCER produces very little noise in operation.

### Type- **BC2** Dual Balance module

#### ● Dual Balancing

The Dual Balance Module with its 2 regulators allows the balancing of 2 different weights, which provides easier transfer or mounting of load.

- Full stroke balancing by hand.
- 2 different weights can be balanced.
- 2 different kinds of balanced weight set in advance can be changed by pushing button on pendant.

Weight switching button

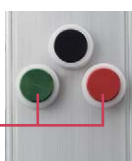

#### Optional design

Bracket

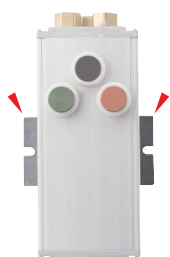

Knob (for BC2-H)



Coil hose



EHB-85+BC2

Dual Balance module



Switching button



Control module	Model	Hose	Weight	Body
Dual Balance module	BC2	Straight hose×3	4kg	EHB-50S(C),50(C),85(C),
Dual Balance module	BC2-H	Straight hose×3	4kg	130(C),270CR

#### Specification

( ) Show performances of the chain type

Model	Air pressure (MPa)	Max lifting capacity (kg)	Stroke (m)	Weight (kg) (*)	Cable dia (Wire rope type)	Chain size×Fall (Chain type)	Air inlet
EHB-50S EHB-50SC	0.7	55	0.7 (0.65)	21 (20)	φ4.76	4.0×1	Rc 3/8
	0.6	48					
	0.5	40					
EHB-50 EHB-50C	0.7	55	1.9 (1.8)	28 (29)			
	0.6	48					
	0.5	40					
EHB-85 EHB-85C	0.7	90	1.9 (1.8)	29 (30)			
	0.6	75					
	0.5	62					
EHB-130 EHB-130C	0.7	140	1.9 (1.8)	36 (37)			
	0.6	120					
	0.5	100					
EHB-270CR	0.7	270	0.9	43	—	4.0×2	
	0.6	230					
	0.5	190					
	0.4	150					

(\*) Weight: Without module



#### ● Dual Balance

2 weights whose range is from 0kg to Max lifting capacity can be set to regulator. The loads with this 2 different weights can be balanced.

#### ● DOWN STOP

Hung load will go down slowly when the air supply is cut off or silver hose is broken.

#### ● Energy-saving design

Air consumption of AIR BALANCER is only 1/7 of that of AIR HOIST. (comparing our existing model)

#### ● Clean design

No lubrication is needed and produces no oil mist.

#### ● Quiet design

With no air motor, AIR BALANCER produces very little noise in operation.

## Type-BC1 Single Balance module

### ● Single Balancing

The hung load will be balanced after the regulator is set to the weight.

This module makes it easy for an operator to lift and lower a load.

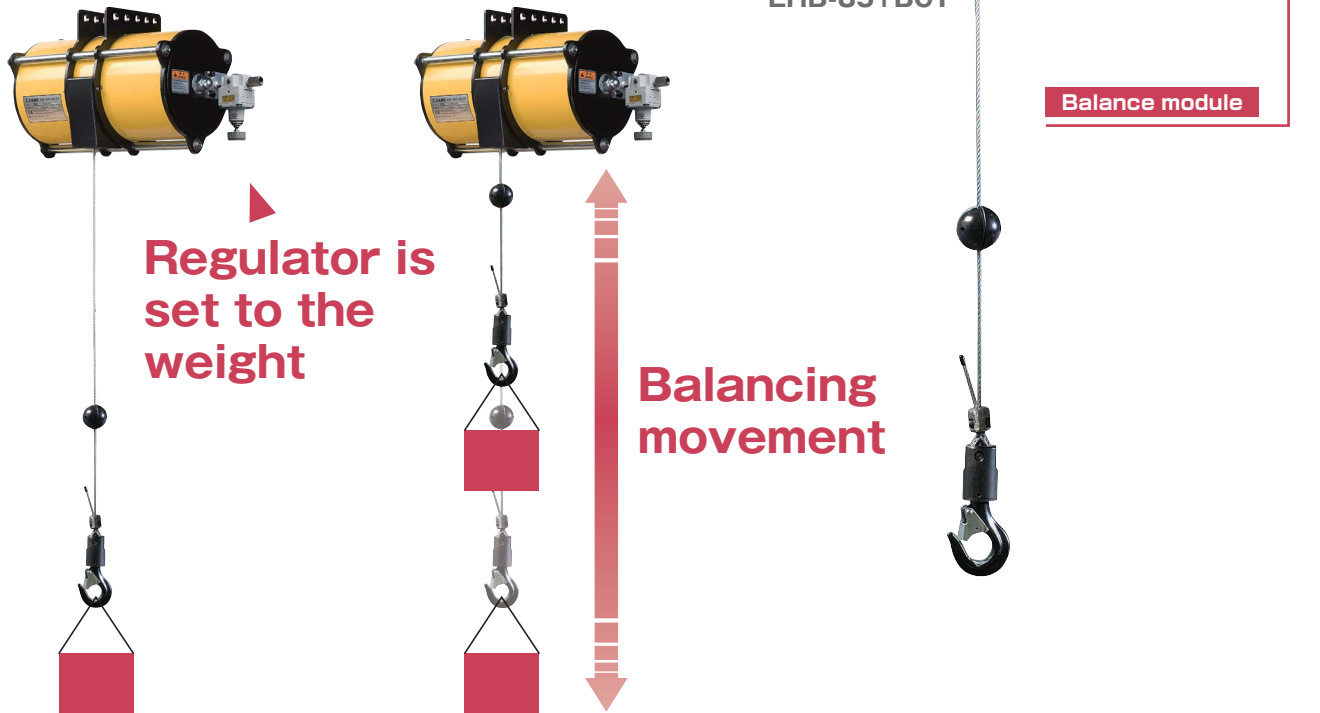

Control module	Model	Weight	Body
Single Balance module	BC1	1kg	EHB-50S(C),50(C),85(C),130(C),270CR

### Specification

( ) Show performances of the chain type

Model	Air pressure (MPa)	Max lifting capacity (kg)	Stroke (m)	Weight (kg) (*)	Cable dia (Wire rope type)	Chain size×Fall (Chain type)	Air inlet
EHB-50S EHB-50SC	0.7	55	0.7 (0.65)	21 (20)	φ4.76	4.0×1	Rc 3/8
	0.6	48					
	0.5	40					
EHB-50 EHB-50C	0.7	55	1.9 (1.8)	28 (29)			
	0.6	48					
	0.5	40					
EHB-85 EHB-85C	0.7	90	1.9 (1.8)	29 (30)			
	0.6	75					
	0.5	62					
EHB-130 EHB-130C	0.7	140	1.9 (1.8)	36 (37)			
	0.6	120					
	0.5	100					
EHB-270CR	0.7	270	0.9	43	—	4.0×2	
	0.6	230					
	0.5	190					
	0.4	150					

(\*) Weight: Without module

**POINT**

#### ● Single Balance

Range of 0kg to Max lifting capacity can be balanced.

#### ● DOWN STOP

Hung load will go down slowly when the air supply is cut off.

#### ● Energy-saving design

Air consumption of AIR BALANCER is only 1/7 of that of AIR HOIST. (comparing our existing model)

#### ● Clean design

No lubrication is needed and produces no oil mist.

#### ● Quiet design

With no air motor, AIR BALANCER produces very little noise in operation.

#### NOTICE

Suspending load will go down slowly with time if the air supply is stopped.

### Type- **MS-ATC** Hoisting for at-hand operation

#### ● Much smoother operation

UP and Down button and handle are equipped on lower hook. Comparing with independent pendant control, load lifts and lowers smoother and stably.



Hook built-in pendant for operation

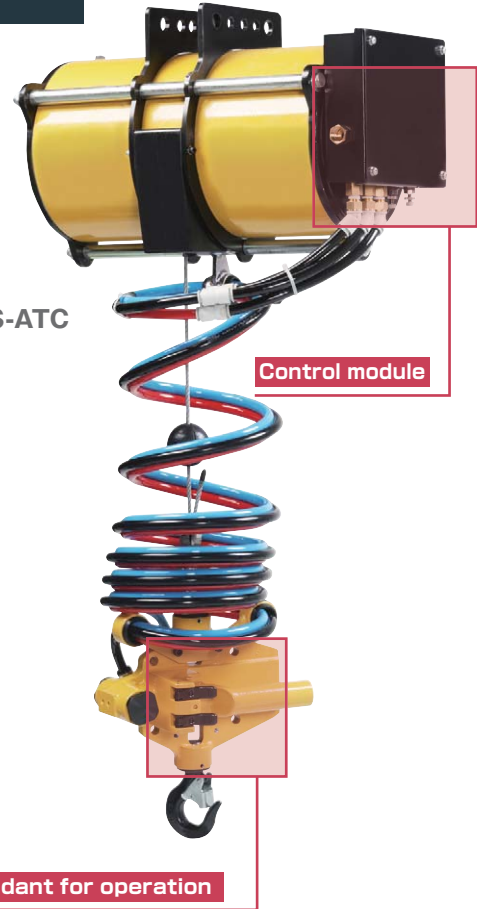

EHB-85+MS-ATC

Control module

Pendant for operation

Control module	Model	Hose	Operation	Weight	Body
Hoisting	MS-ATC	Coil hose×3	Pendant	6kg	EHB-50S(C),50(C),85(C),130(C)

### Specification

( ) Show performances of the chain type

Model	Air pressure (MPa)	Max lifting capacity (kg)	Stroke (m)	Weight (kg) (*)	Cable dia (Wire rope type)	Chain size×Fall (Chain type)	Air inlet
EHB-50S EHB-50SC	0.7	55	0.7 (0.65)	21 (20)	φ4.76	4.0×1	Rc 3/8
	0.6	48					
	0.5	40					
	0.4	32					
EHB-50 EHB-50C	0.7	55	1.9 (1.8)	28 (29)			
	0.6	48					
	0.5	40					
	0.4	32					
EHB-85 EHB-85C	0.7	90	1.9 (1.8)	29 (30)			
	0.6	75					
	0.5	62					
	0.4	50					
EHB-130 EHB-130C	0.7	140	1.9 (1.8)	36 (37)			
	0.6	120					
	0.5	100					
	0.4	80					

(\*) Weight: Without module

**POINT**

#### ● at-hand operation

This module is pendant type which can be operated at-hand and enables you to control hoisting and lowering with stable condition of the load.

#### ● DOWN STOP

Added safety measure. Hung load will not fall even if the air supply is cut off or when hoses are broken.

#### ● Energy-saving design

Air consumption of AIR BALANCER is only 1/7 of that of AIR HOIST. (comparing our existing model)

#### ● Clean design

No lubrication is needed and produces no oil mist.

#### ● Quiet design

With no air motor, AIR BALANCER produces very little noise in operation.



# Load Chain type

- **AIR BALANCER with alloy steel loadchain.**  
Tougher and more durable.

## Double chain type (CR)

### Single chain type (C)

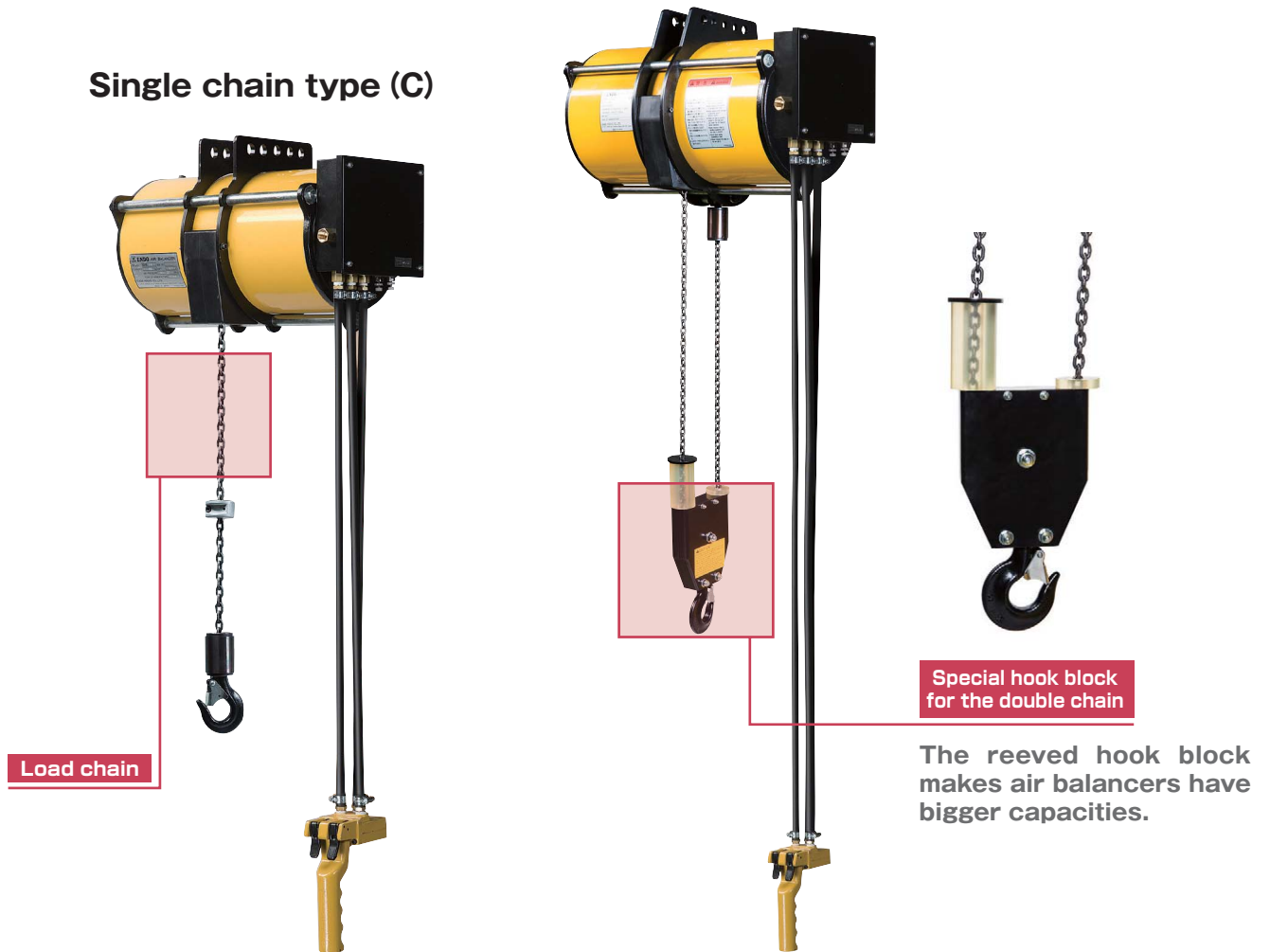

## Specification

Model	Stroke (m)	Weight (kg)	Size×Fall	Control module								
				MS-A	MS-AG	MS-ATC	MS/MSS	ABC-5P-B	ABC-5G-B	BC1	BC2	
EHB-50SC	0.65	20	4.0×1									
EHB-50C	1.8	29		✓	✓	✓	✓	✓	✓	✓	✓	
EHB-85C	1.8	30										
EHB-130C	1.8	37										
EHB-270C	1.7	44	4.0×2	✓			✓					
EHB-270CR	0.9	43		✓			✓	✓		✓	✓	
EHB-450CR	0.85	50		✓			✓					

# JIB CRANE

## ● Rail system for less space

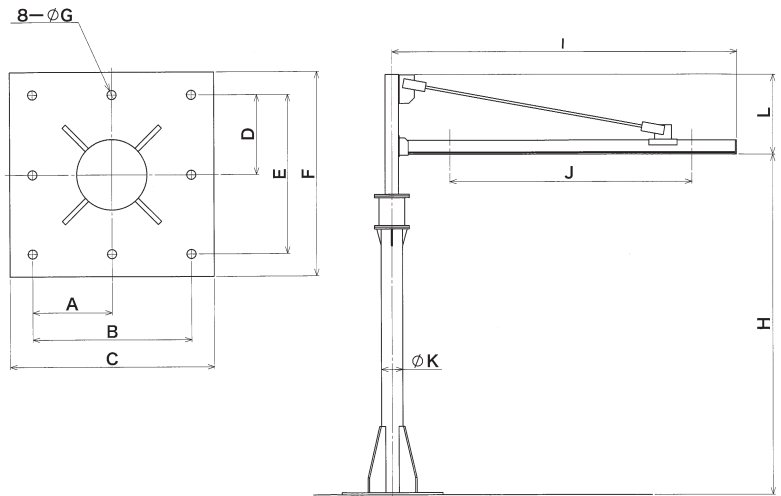
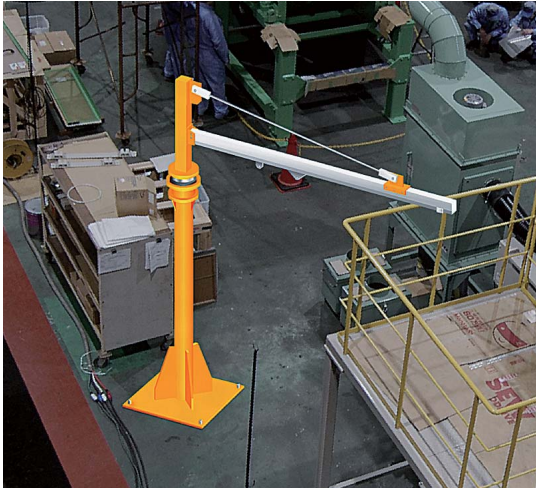

## Dimensions

Model	A (mm)	B (mm)	C (mm)	D (mm)	E (mm)	F (mm)	G (mm)	H (mm)	I (mm)	J (mm)	K (mm)	L (mm)	Weight (kg)
EJS-2-20-300	230	460	500	230	460	500	φ20	2,000	2,095	1,140	φ216.8	700	300
EJS-2-30-265	230	460	500	230	460	500	φ20	3,000	2,095	1,315	φ216.8	700	265
EJS-3-20-170	230	460	500	230	460	500	φ20	2,000	3,095	2,235	φ216.8	900	170
EJS-3-30-150	230	460	500	230	460	500	φ20	3,000	3,095	2,235	φ216.8	900	150
EJB-2-20-400	280	560	600	280	560	600	φ20	2,000	2,110	1,140	φ267.4	700	400
EJB-2-30-400	280	560	600	280	560	600	φ20	3,000	2,110	1,140	φ267.4	700	400
EJB-3-30-250	280	560	600	280	560	600	φ20	3,000	3,110	2,235	φ267.4	900	250
EJB-4-30-120	280	560	600	280	560	600	φ20	3,000	4,110	3,235	φ267.4	900	120

※More models are available. Feel free to ask us.

## Attachment

### ■ Pantograph type



### ■ 2 points hook type

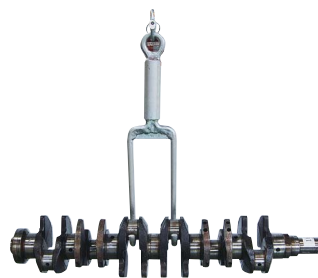

※We can customize for your request.

## An excellent transfer system employing the benefits of aluminum and rail system

- ① Great movability. Enables load transfer with the shortest distance travel and thus faster working time.
- ② Standardization for parts makes it easy for relocation and expansion.
- ③ The parts come with kits and are joint using bolts; easy to assemble and repair.
- ④ Compared to steel rail, aluminum is lighter and stronger. With anodized treatment, our aluminum rails are more corrosive resistant, more durable, and looks better.
- ⑤ Precision machining on our rails and resin wheels allow smooth travel with little friction.

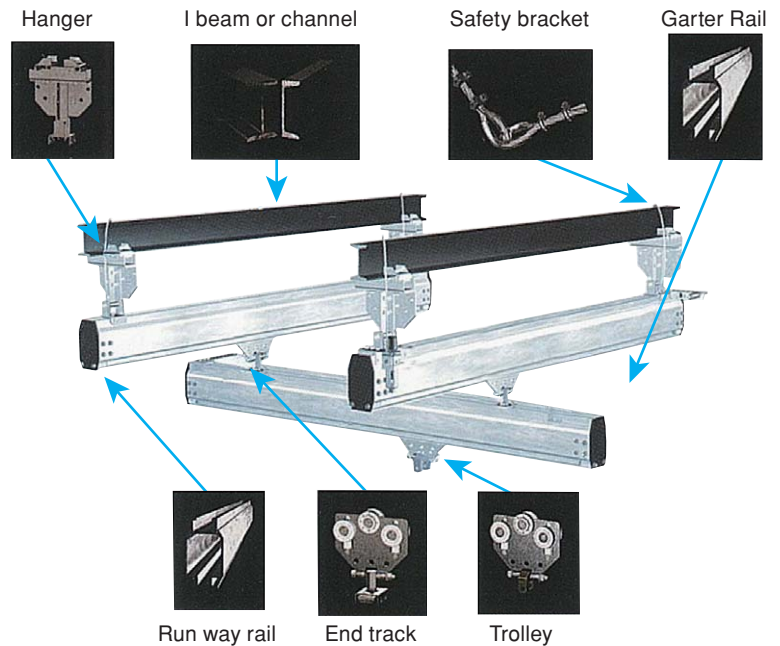

## Aluminum alloy rail

Model	Measurement (mm)	Unit weight	Rail length
TR2000		3.6kg/m	2inch
RAD4110		6.44kg/m	4inch
RAD7510		12.26kg/m	8inch

There are various trolley suited to your needs. Special trolleys are available for 2, 4 and 8 inch rails. Maximum loadings are;  
 2 inch ... 180kg  
 4 inch ... 250kg  
 8 inch ... 490kg

### Relation between lifting span and lifting load Unit:Kgf

Rail length	TR2000	RAD4110	RAD7510
	Lifting load	Lifting load	Lifting load
1m	200	500	500
2m	100	500	500
3m	45	250	500
4m	25	140	500
5m	16	90	470
6m	11	60	330

### Accessories

#### EHB Trolley

(Applicable width of beam 75, 100mm)



#### Dimensions

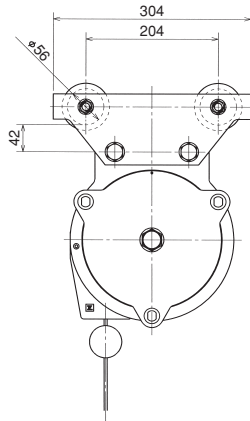

Body	Part No.
Wire rope Single chain	LHP001899
Double chain	LHP002714

#### EHB Hook set



#### Dimensions

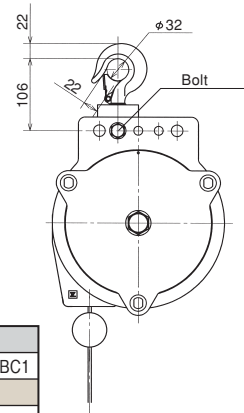

Body	Part No.	Correspond module
Wire rope Single chain	LHP001900	MS, MS-A, MS-AG, MS-ATC, BC1
	LHP001991	MSD
Double chain	LHP002146	BC2, ABC
	LHP002691	MS, MS-A, BC1
	LHP002700	BC2, ABC-5P-B

### Dimensions

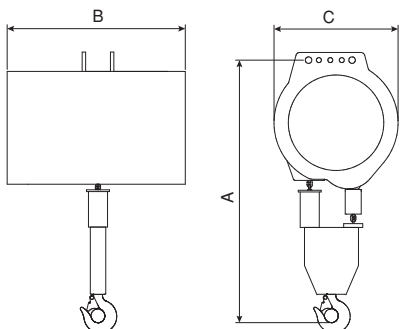
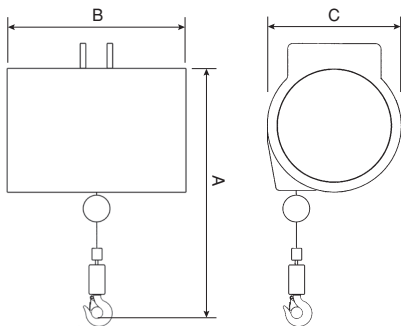

Double chain type

(\* ) shows dimensions of chain type.

Model	Module	Dimensions (mm)			
		A		B	C
		MIN.	MAX.		
EHB-50S EHB-50SC	MS	526(517)	1226(1167)	337	211
	MS-A	526(517)	1226(1167)	362	211
	MS-AG	921(912)	1621(1562)	362	211
	MS-ATC	704(695)	1404(1345)	362	211
	ABC-5P-B	526(517)	1226(1167)	478	363
	ABC-5G-B	811(802)	1511(1452)	478	363
	BC1	526(517)	1226(1167)	416	211
EHB-50 EHB-50C	BC2	526(517)	1226(1167)	347	319
	MS	526(517)	2426(2317)	473	211
	MS-A	526(517)	2426(2317)	498	211
	MS-AG	921(912)	2821(2712)	498	211
	MS-ATC	704(695)	2604(2495)	498	211
	ABC-5P-B	526(517)	2426(2317)	516	363
	ABC-5G-B	811(802)	2711(2602)	516	363
EHB-85 EHB-85C	BC1	526(517)	2426(2317)	552	211
	BC2	526(517)	2426(2317)	495	319
	MS	570(560)	2470(2360)	466	252
	MS-A	570(560)	2470(2360)	491	252
	MS-AG	965(955)	2865(2755)	491	252
	MS-ATC	746(736)	2646(2536)	491	252
	ABC-5P-B	570(560)	2470(2360)	516	386
EHB-85D	ABC-5G-B	853(843)	2753(2643)	516	386
	BC1	570(560)	2470(2410)	545	252
	BC2	570(560)	2470(2410)	495	340
	MSD	570	2470	520	326
	MS	652(629)	2552(2429)	469	305
	MS-A	652(629)	2552(2429)	494	305
	MS-AG	1020(997)	2920(2797)	494	305
EHB-130 EHB-130C	MS-ATC	803(780)	2703(2580)	494	305
	ABC-5P-B	652(629)	2552(2429)	516	440
	ABC-5G-B	910(887)	2810(2687)	516	440
	BC1	652(629)	2552(2429)	547	305
	BC2	652(629)	2552(2429)	495	393
	MSS	652(629)	2452(2329)	591	305
	MS-A	652(629)	2452(2329)	616	305
EHB-270 EHB-270C	MS	688	1538	469	325
	MS-A	688	1588	494	325
	ABC-5P-B	688	1588	516	462
	BC1	688	1588	547	325
	BC2	688	1588	495	418
EHB-270CR	MSS	688	1538	591	325
	MS-A	688	1538	616	325
EHB-450CR	MSS	688	1538	591	325
	MS-A	688	1538	616	325